



# Feedback control of vortex shedding from two tandem cylinders

D. Wolfe, S. Ziada\*

*Department of Mechanical Engineering, McMaster University, Hamilton, Ont., Canada L8S 4L7*

Received 31 May 2001; accepted 22 October 2002

---

## Abstract

The effect of feedback control on vortex shedding from two tandem cylinders in cross-flow is investigated experimentally. The objective is to reduce the downstream cylinder response to vortex shedding and turbulence excitations. Feedback control is applied to a *resonant case*, where the frequency of vortex shedding coincides with the resonance frequency of the downstream cylinder, and to a *nonresonant case*, in which the shedding frequency is about 30% higher than the downstream cylinder resonance frequency. A “synthetic jet” issuing through a narrow slit on the upstream cylinder is employed to impart the control effect to the flow. The effect of open-loop control, using pure tones and white noise to activate the synthetic jet, is also examined. It is demonstrated that feedback control can significantly reduce the downstream cylinder response to both *vortex shedding and turbulence excitations*. For example, the cylinder response is reduced by up to 70% in the *resonant case* and 75% in the *nonresonant case*. Open-loop control also can reduce the cylinder response, but is less effective than feedback control. The frequency of vortex shedding is found to increase substantially when white noise is applied. This increase in the shedding frequency is higher than the largest frequency shift that could be produced by open-loop tone excitation.

© 2003 Elsevier Science Ltd. All rights reserved.

---

## 1. Introduction

When a cylinder is placed in the wake of another in cross-flow, the so-called *tandem arrangement*, its unsteady loading becomes dependent not only on the flow activities in its wake, but also on those in the wake of the upstream cylinder. If the gap between the cylinders is sufficiently large (Zdravkovich, 1985), the vortices generated in the gap can be quite strong because of their impingement on the downstream cylinder and the resulting upstream feedback which enhances vortex formation. Rockwell and Naudascher (1979) describe the nature of this upstream feedback in detail. The downstream cylinder also sheds vortices, which may possess a great deal of coherence because they are affected by the gap vortices. As a result, the unsteady fluid forces induced by vortex shedding and acting on both cylinders, and particularly those acting on the downstream cylinder, could be sufficiently large to cause dangerous vibration (King, 1977). Flow across two tandem cylinders has received considerable attention by researchers because of its importance to industrial aerodynamics, wind engineering and marine applications. Arie et al. (1983) provide comprehensive data of lift, drag and correlation coefficients for tandem cylinders, and Zdravkovich (1977, 1985, 1987) published excellent reviews of the state of knowledge of flow across two cylinders in various arrangements. The present work focuses on the feasibility of employing a feedback control means to reduce the response of the downstream cylinder to vortex shedding and turbulence excitations.

---

\*Corresponding author. Tel.: +1-905-525-9140; fax: 1-905-572-7944.  
E-mail address: ziad@mcmaster.ca (S. Ziada).

While early studies employed active control methods, such as acoustic excitation, to investigate the characteristics of disturbance growth in free shear layers and wakes (see, for example, Freymuth, 1966; Peterka and Richardson, 1969; Miksad, 1972), recent investigations utilized external forcing, with and without amplitude and frequency modulations, to either suppress natural vortex shedding or alter its frequency (e.g., Blevins, 1985; Roussopoulos, 1993; Nakano and Rockwell, 1993, 1994). Several forms of external excitation have been used including sound (Roussopoulos, 1993; Huang, 1996) electromagnetic and piezoelectric actuators (Wiltze and Glezer, 1993) or vibration of the bluff body itself in the form of transverse or rotational oscillations (Tokumar and Dimotakis, 1991; Nakano and Rockwell, 1993, 1994; Schumm et al., 1994; Warui and Fujisawa, 1996).

Feedback control techniques have been used successfully to suppress global flow oscillations, which are generated by a convective flow instability, coupled with an upstream feedback due to flow impingement or system resonance (Ziada, 1999). Almost invariably, the control effect was focused upon the initial region of flow separation to neutralize the self-induced upstream effect. Examples include suppression of jet-edge and jet-slot oscillations (Ziada, 1995), acoustic resonance in cavities and piping systems (Huang and Weaver, 1991; Sarno and Franke, 1994; Cattafesta III et al., 1997; Ziada, 2001) and flow-excited structural resonance (Huang and Weaver, 1994; Ziada, 2002) and others.

In the case of wake shedding, which is generated by an absolute flow instability (Huerre and Monkewitz, 1990), suppression of vortex shedding by active means has proved to be more difficult. However, substantial progress has been achieved, e.g., the vortex-shedding process could be altered, if not suppressed or weakened. Blevins (1985) used high-amplitude sound excitation, generated by loudspeakers mounted on the test-section wall, to shift the frequency of vortex shedding from a rigid cylinder by an amount up to 8%. Many researchers performed analogous studies focussing on the effect of *open-loop control*, in which the excitation is not derived from the wake response. Hsiao and Shyu (1991) imposed sound through a narrow slit on the cylinder at the transition wave frequency. Williams et al. (1992) used two rows of holes instead of a slit and applied sound at 1.8 times the shedding frequency. Nakano and Rockwell (1993, 1994) and Schumm et al. (1994) used cylinder oscillation at controlled frequencies and amplitudes. In all of these studies, and others, vortex shedding was modified, and sometimes weakened, by the imposed excitation.

Studies of *feedback control* of wake shedding are still rare in the literature. Roussopoulos (1993) has been able to increase the critical Reynolds number for the onset of vortex shedding from a cylinder by about 20% of its value without control. At higher Reynolds numbers, it was not possible to suppress vortex shedding, although the response of a hotwire in the near wake was deceptively reduced. Huang (1995, 1996) used the signal of a hotwire in the wake to activate sound forcing through a narrow slit on one side of the cylinder. For a Reynolds number range of 4000–8000, he reported that relatively low sound levels were the only range that had significant effect on the velocity fluctuation in the wake (a reduction of up to 12 dB). Another interesting aspect of Huang's research is that only one side of the cylinder was excited. He also found that the slit had to be positioned upstream of the flow separation to affect control. Warui and Fujisawa (1996) also used feedback control and were able, by means of cylinder oscillation, to reduce the turbulence intensity in the wake by 30%.

In the present study, open- and closed-loop control techniques are used to affect vortex shedding from two tandem cylinders in cross-flow. The objective is to reduce the downstream cylinder response to vortex shedding and turbulence excitations. Based on preliminary tests of several gaps, the gap between the cylinders is chosen to be 4.5 cylinder diameters in order to maximize the vortex-shedding excitation on the downstream cylinder. A "synthetic jet" is induced through *one slit* on the upstream cylinder by means of loudspeakers acting on the cylinder interior. The speakers are activated by either the signal of a force transducer, sensing the lift on the downstream cylinder, or by the signal of a hotwire, feeling the velocity fluctuation in the gap between the cylinders. The effect of feedback control is studied at two flow velocities for which the frequency of vortex shedding is either equal to, or 30% higher than the resonance frequency of the downstream cylinder. These two test cases are referred to hereafter as the *resonant* and the *nonresonant* cases, respectively.

## 2. Experimental set-up

The experiments were performed in an open-circuit, suction wind tunnel. The tunnel has an octagonal cross-section of  $0.31 \text{ m}^2$  and a maximum flow velocity of 25 m/s. It is approximately 10.5 m in length, with a contraction section of area ratio 3.8 at its inlet. Screens and honeycomb are used at the contraction inlet, yielding an average upstream turbulence intensity between 0.5% and 1%, depending on the flow velocity. The velocity profile upstream of the test section is flat within 2% outside the boundary layer. As shown in Fig. 1, two tandem cylinders were positioned in the test-section with a spacing of  $4.5D$ , where  $D$  is the diameter of the cylinders. This spacing was chosen based on preliminary tests, which showed that the fluctuating lift forces on the downstream cylinder were strongest at this

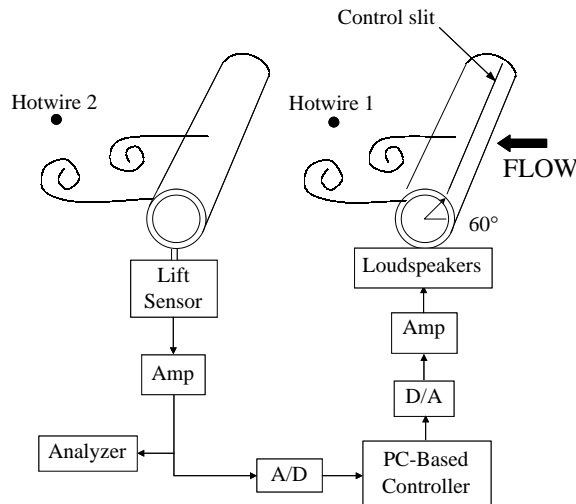

Fig. 1. Schematic presentation of the test set-up.

spacing; in agreement with the data reported by [Arie et al. \(1983\)](#). Both cylinders were made of polished aluminium with an outer diameter of 40 mm and a wall thickness of 3 mm. The aspect ratio ( $L/D$ ) of this configuration was 15.

The upstream cylinder was 617 mm in length and was rigidly mounted to the wind tunnel sidewalls. A narrow slit, 0.75 mm in width, was cut along the cylinder length, excepting 20 mm at each end. The slit was oriented at an angle of  $60^\circ$  from the front stagnation point because [Huang \(1996\)](#) found the energy needed for control to be minimum at this angle. Holes matching the inner diameter of the upstream cylinder were cut in the test-section to allow loudspeakers to be mounted on each end. Adapters were fashioned to provide a gradual transition from the loudspeaker cone diameter of 130 mm to the cylinder inner diameter of 34 mm. The loudspeakers (Kenwood KGC-W1602 subwoofer) were powered in phase by a two-channel amplifier type RAMSA WP-1200.

The downstream cylinder was 1163 mm in length, passing through 42 mm holes in both sidewalls of the acrylic test-section, providing 1 mm of clearance around the circumference of the cylinder. The cylinder is mounted on a very robust steel frame that is isolated from the wind tunnel. The clearance of 1 mm and isolated mounting were necessary to prevent transmission of the vibrations from the tunnel structure to the cylinder.

Both ends of the downstream cylinder were pivoted on the isolated steel frame by means of two ball bearings on each side, such that the cylinder was effectively simply supported at both ends. However, a piezoelectric force sensor (PCB 208B) was integrated into the mount of one side. In order to measure the lift force, the sensor's axis of measurement was aligned in the direction of cylinder lift, i.e., the vertical direction. Calibration tests showed that the error introduced in the force transducer signal due to its response to drag forces was less than 1.4%.

Because of the large dimensions of the supporting steel frame, the downstream cylinder was rather long; allowing it to vibrate at its first bending mode which had a frequency of 71 Hz. However, the vibration amplitude was always smaller than the 1 mm clearance to test-section wall, except when the vibration was enhanced by active control means. As it will be shown later, this small amplitude vibration of the downstream cylinder did not cause any discernible change in the vortex-shedding process. More importantly, the tube response masked the transmitted fluid force to the transducer. In order to convert the force measured by the transducer to dynamic fluid force or lift coefficient, the tube was modelled as a single degree of freedom oscillator, and the classical force transmissibility coefficient ([Thomson and Dahleh, 1998](#)) was used to estimate the dynamic lift coefficient. However, in order to delineate the effect of control on the response of the downstream cylinder, all test results in this paper are given in terms of "unconverted" or transmitted force as measured by the force transducer.

The velocity fluctuations were measured by means of hotwires in conjunction with a two-channel anemometer (DISA 56C01). Placement of the hotwires in the *streamwise* direction was chosen based on comparison with published research on vortex shedding from two tandem cylinders ([Mahir and Rockwell, 1996](#)). One hotwire (Hw1) was placed between the cylinders, 2.75 diameters upstream of the downstream cylinder. The second hotwire (Hw2) was placed 5 diameters downstream of the downstream cylinder. Both hotwires were placed at the transverse locations that provided the strongest velocity-fluctuation signal. Surveys of the fluctuation velocity distributions with and without control ([Wolfe, 2000](#)) showed that the optimal *transverse* locations of the hotwires did not change with the application of control.

The signals of the hotwires and the force sensor were sent to a four-channel spectrum analyzer (HP 35670A) for recording and on-line spectral analysis. The controller used in this research was housed on a Pentium III computer and programmed in Simulink. It allowed the adjustment of gain and time delay of the controller output. The time-delay adjustment produced a phase change in the control signal. The signal from Hw1 and the force sensor were captured at a sampling rate of 20 kHz by a 12 bits A/D-D/A card (Quanser MQ3 DAQ) and alternately used as input to the controller, which activated the speakers. The gain and delay settings for each test condition that achieved maximum attenuation of fluctuating force were located through a systematic search. A more detailed description of the experimental apparatus and control system can be found in Wolfe (2000).

### 3. Uncontrolled response of selected test cases

Two flow velocities were chosen for control experiments. Spectra showing the characteristics of these two test cases are presented in Fig. 2. The lower flow velocity was chosen because the frequency of vortex shedding was equal to the resonance frequency of the downstream cylinder; causing a resonant response of the cylinder at 71 Hz. The higher flow velocity was chosen near the maximum flow speed of the tunnel. At this test condition, the frequency of vortex shedding was separated as much as possible from the resonance frequency of downstream cylinder.

The lift coefficients for each test case were estimated and compared to clarify whether or not the cylinder vibration in the resonant case enhances vortex shedding and the resulting lift force on the downstream cylinder. As mentioned earlier, the spectra of fluid (or lift) force on the downstream cylinder were first calculated from the force transducer spectra using the transmissibility coefficient (Thomson and Dahleh, 1998) given by

$$F_T/F_L = \{[1 + (2\zeta r)^2]/[(1 - r^2)^2 + (2\zeta r)^2]\}^{1/2}, \quad (1)$$

where  $F_L$  is the lift force on the cylinder,  $F_T$  is the transmitted force to transducer,  $\zeta$  is the damping coefficient, and  $r$  is the frequency ratio. The dynamic lift coefficient,  $C_L$ , was then estimated from total r.m.s. amplitude of the lift spectrum by means of the following formula:

$$F_{r.m.s.} = \frac{1}{2} \rho A U^2 C_L, \quad (2)$$

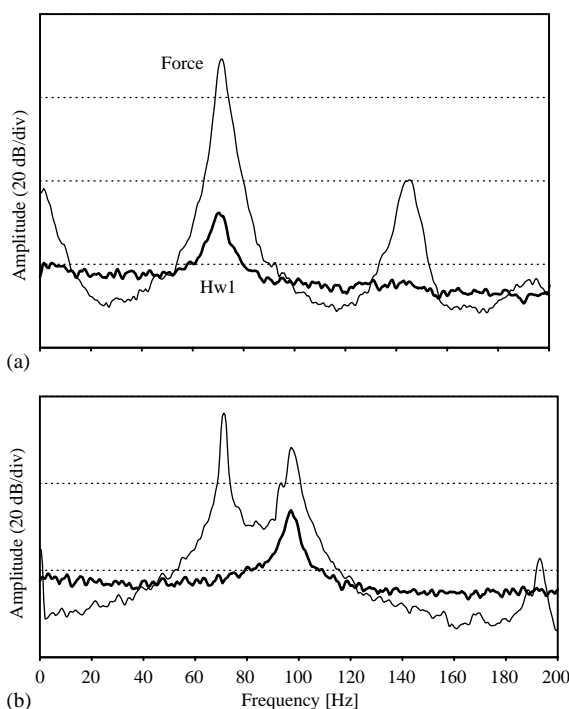

Fig. 2. Typical spectra of hotwire and force signals showing the characteristics of the two test cases: (a) resonant case, 15.4 m/s,  $Re = 41\,100$ ; (b) nonresonant case, 21.7 m/s,  $Re = 57\,900$ . Thin line: force; thick line: hotwire signal.

where  $F_{r.m.s.}$  is the total r.m.s. amplitude of lift force,  $\rho$  is fluid density,  $A$  is the projected surface area of the cylinder and  $U$  is free stream flow velocity. For the present purpose of comparison, it is assumed that the fluid force is perfectly correlated along the whole span of the cylinder. Force spectra taken at the highest flow velocity of the tunnel were used to determine the damping coefficient by means of the half power bandwidth method (Thomson and Dahleh, 1998). At this velocity, the downstream cylinder response at its resonance frequency is generated by broadband turbulence excitation as can be seen in Fig. 2(b). This method was used, rather than the logarithmic decrement method, to take into account the damping generated by the flow, which is substantial as discussed by Blevins (1990). This method gave an average value of  $\zeta = 1.3\%$ .

As can be seen in Table 1, the lift coefficient obtained for the resonant case is only slightly higher than that of the nonresonant case. This suggests that the vibration of the downstream cylinder, which is much more pronounced for the resonant case, has little effect, if any at all, on the strength or the correlation length of vortex shedding from the upstream cylinder. A similar conclusion may be drawn from scrutiny of the hotwire spectra given in Fig. 2. The shedding peak of the resonant case does not show any enhancement that could be attributed to vibration of the downstream cylinder. Tanida et al. (1973) reported similar results for two tandem cylinders with similar spacing ratio. He found that motion of the downstream cylinder does not affect the characteristics of the upstream flow.

The estimated values of lift coefficient given in Table 1 are substantially smaller than those reported in the literature (Arie et al., 1983). This is to be expected because the values given by Arie et al. are calculated from *local* pressure measurements with the assumption that these pressure fluctuations are in-phase (i.e., perfectly correlated) along the whole length of the cylinder.

#### 4. Control of the resonant case

##### 4.1. Feedback control results

The effect of time delay of the controller is illustrated in Fig. 3, which shows the ratio of the maximum spectral amplitude of transmitted force with control to that without control for several values of controller gain. The amplitude ratio of unity corresponds to the amplitude level without control, providing a basis for comparison. Three sets of data for gains of 2, 4 and 8, using the force signal as the control input, are included to show the improved cancellation, or enhancement, at higher gains. Results using the signal of the hotwire between the cylinders (Hw1) as the control input with an optimal gain of 8 are also included Fig. 3. There is a cyclic relationship between controller delay and force amplitude. As the time-delay changes, the force amplitude goes through cycles of attenuation and enhancement. Fig. 3 shows slightly more than one full cycle, with two minima at delays near 1 and 14 ms. The difference in the delay times of these minima is roughly equal to the period of the observed oscillations at 71 Hz, which is 14 ms. As the controller delay is changed from 1 to 14 ms, the phase of the controller output at 71 Hz changes by  $360^\circ$ , with respect to the force signal. At 14 ms, vortex shedding at 71 Hz is being controlled by a signal that is *delayed by one full cycle*. This delayed signal, at the optimal gain of 8, reduces the force amplitude to about 40% of its original value without control, whereas a time lag of 1 ms reduces it to 30% of the original value. Thus, while a delay of 1 ms seems to be an optimal setting, a delay by a whole cycle still achieves significant control. In other words, the effect of the controller does not have to be instantaneous, it can be delayed by a complete cycle. The implications and importance of this finding are discussed in the following.

Since the spectral peak of vortex shedding is seen to be broad banded in the hotwire spectrum shown in Fig. 2(a), the frequency and strength of the vortices impinging on the downstream cylinder must both ‘wander’ about a mean value as discussed by Blevins (1985). Thus, the frequency and amplitude of the *fluid-dynamic upstream effect* must also exhibit small time-dependent variations about their mean values. The fact that a delay by a whole cycle still achieves significant control means that the “active control feedback” does not have to be instantaneous, or, it does not have to mimic the instantaneous upstream effect of the flow activities at the downstream cylinder. In other words, it is sufficient if it mimics the effect of the preceding cycle, which is not necessarily identical to the effect of the cycle being controlled. The

Table 1  
Lift coefficients and relevant values for both test cases

Flow velocity (m/s)	Reynolds number	Shedding frequency (Hz)	Lift coefficient $C_L$
15.4	41 100	71	0.097
21.7	57 900	97	0.071

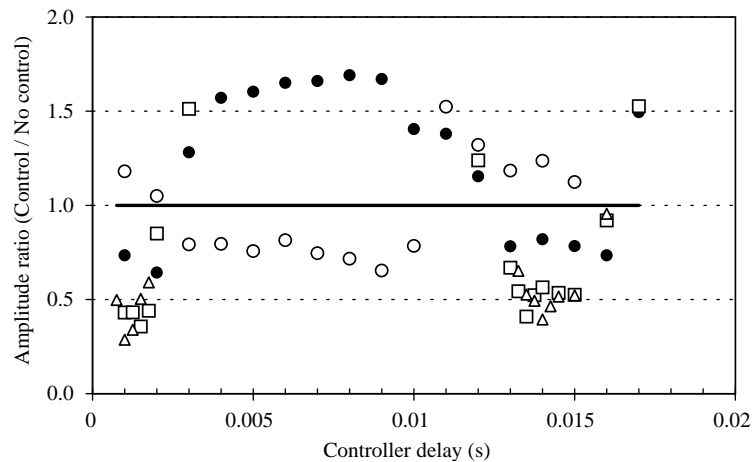

Fig. 3. Summary of 'control/no control' amplitude ratio of the lift force for the resonant case ( $Re = 41\,100$ ). ●, Force signal input, gain = 2; □, gain = 4; △, gain = 8; ○, hotwire input.

feasibility of using longer time delays for control is of practical importance as it may greatly simplify the implementation of the control method in practical applications, especially in those involving high frequencies.

Fig. 3 also shows that enhancement of vortex shedding and force occurs for time delays between 3 and 12 ms, with the force signal as control input. Time delays of 1–2 and 11–15 ms cause enhancement if the hotwire signal is used for control. The range of delay that produces enhancement is much wider than that which produces attenuation for a force signal control input, while a hotwire signal control input seems to produce an opposite effect for the same time delay. The attenuation and enhancement produced with a force signal control input are also significantly larger than those produced by a hotwire signal control input.

Spectra of enhancement produced with the force signal as control input, a controller gain of 4 and a delay of 3 ms, are shown in Fig. 4. These test conditions correspond to the best case of force enhancement without impacting the downstream cylinder on the test-section wall. The force spectrum shows a narrowed peak as well as an upward shift in frequency with control. The hotwire spectra show a similar, but more pronounced, narrowing of the vortex-shedding peak and upward shift in vortex-shedding frequency. The upward shift in the frequency of vortex shedding and the corresponding shift in cylinder response seem to be caused by shear layer transition of the upstream cylinder, which is triggered by the imposed sound from the slit. This phenomenon is addressed in more detail in the section dealing with tone and white noise excitations.

Referring to Fig. 3, the data corresponding to a gain of 2 and a force signal control input exhibit a relatively flat amplitude ratio within the range of enhancement. This is due to the impacting of downstream cylinder on the test-section wall. The amplitude of vibration caused by feedback enhancement is so large that the cylinder displacement exceeds the 1 mm clearance allowed where it passes through the test-section sidewalls. Experiments were not performed at time delays that produced significant enhancement for higher gains (4 and 8) to avoid possible damage to the apparatus.

Experiments using the signal from Hw1 as the control input did not produce results comparable to control using the force signal as the control input. At the optimum settings, the force was reduced to 65% of its original value without control, as it is shown in Fig. 3. The optimal controller gain was 8 for control using Hw1 signal as the control input. This controller gain is not comparable to the controller gain used for the force signal control input. Moreover, the time delay that produces maximum reduction of the force is not the same for control using hotwire and force signals as input. This is because of the different nature of the sensors as well as their different streamwise locations. There is a time delay between the arrival of the vortices to Hw1 and their impingement on the downstream cylinder. It is these differences that cause the optimal time delay for attenuation to differ substantially.

Fig. 5 shows force and hotwire spectra for selected cases of those shown in Fig. 3. The spectra plotted correspond to the optimal delay for maximum suppression in each case. Fig. 5(a) shows force spectra with the scales adjusted to show the harmonics of cylinder response. The plotted spectra, corresponding to optimal control at gains of 4 and 8, show that harmonic peaks are reduced at least as much as the fundamental component at 71 Hz. Fig. 5(a) shows also that the amplitudes of the higher harmonics of the resonance frequency are reduced more with a lower gain of 4, than with a gain of 8. This could be due to amplitude distortion of the loudspeaker at the higher gain of 8.



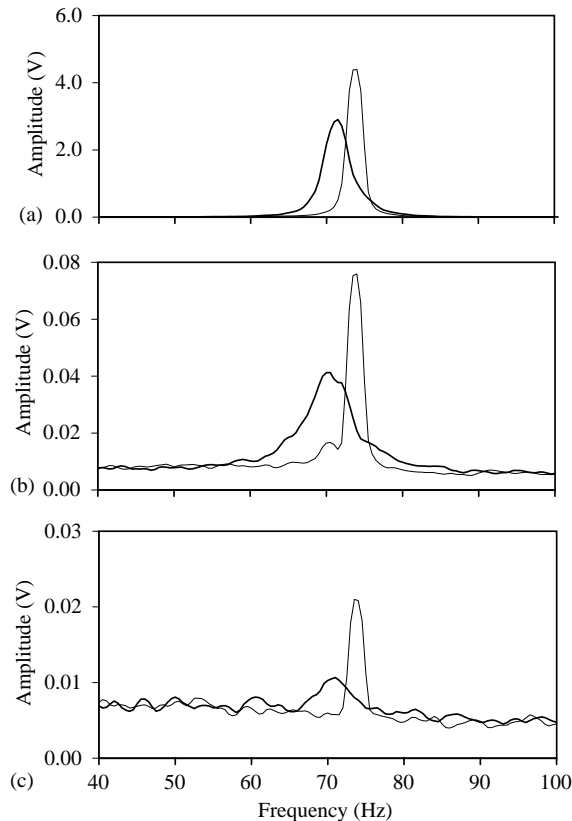

Fig. 4. Spectra showing enhancement of force and hotwire signals for the resonant case: (a) force signal; (b) hotwire between cylinders, Hw1; (c) downstream hotwire, Hw2. Thick line: no control; thin line: with control.

Fig. 5(b)–(d) shows the spectral details of the 71 Hz peak alone. The control spectra show a reduced amplitude of the force peak at 71 Hz but also show a peak emerging at a higher frequency of about 76 Hz. This can be explained by examination of the matching hotwire spectra. Similar to the case of enhancement control discussed in Fig. 4, the hotwire spectra depicted in Figs. 5(c) and (d) show that the frequency of vortex shedding has been shifted upwards. The amplitude of the frequency-shifted vortex-shedding peak is increased in almost every case. In addition, the frequency-shifted peak is narrower than the peak at the original frequency. This narrowness of the peak must be attributed to a reduced ‘frequency wander’ of the natural vortex shedding due to the applied sound. Blevins (1985) reported a similar effect of sound on vortex shedding from a *single* cylinder. As it has been mentioned earlier, the shift of vortex shedding to a higher frequency seems to be caused by transition of boundary layer on the upstream cylinder.

The effect of changes in gain for control using the force signal as control input seems to be more pronounced at low gains than at high gains. The difference between the results for gains of 2 and 4 is quite large, as shown in Figs. 3 and 5. A second doubling of gain, from 4 to 8, improves control, but not by a large amount. It is possible that distorted loudspeaker response at high gains contributes to this effect. However, it is also possible that, even in the absence of loudspeaker distortion, the effect of control would plateau and then the amount of attenuation would start to decrease as the gain is increased beyond an optimum value. This latter feature has been reported for other applications of feedback control of flow oscillations. For example, in the case of jet-edge oscillation, Ziada (1995) observed that as the controller gain was increased, the oscillation amplitude was initially decreased, but then started to increase as the gain was increased beyond an optimum value.

The test results discussed so far show that *no reduction* in vortex-shedding strength has been achieved. Therefore, it seems logical to conclude that the reduction in transmitted force is due to the shift in vortex-shedding frequency when the control is applied. In other words, the downstream cylinder is excited at a frequency that is farther away from its resonance frequency, and thereby its resonant response and the transmitted force are smaller, despite the apparent

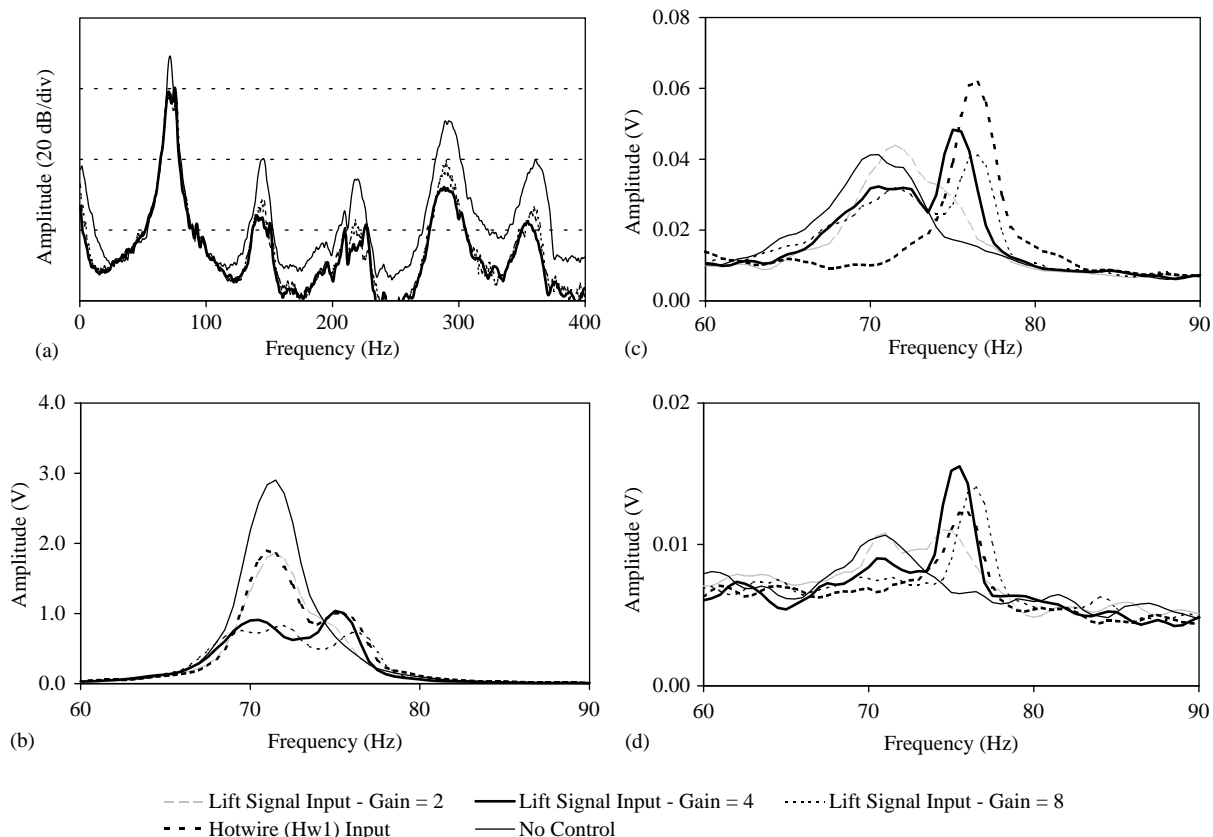

Fig. 5. Spectra of the resonant case at the optimum settings of controller time delay: (a) force spectra for an extended scale to show the harmonic components; (b) force spectra, close-up to show changes in resonance peak with control; (c) hotwire between cylinders (Hw1); and (d) downstream hotwire (Hw2). —, no control; force signal input: ---, gain 2; —, gain 4; ···, gain 8; - · -, hotwire input.

increase in the strength of vortex shedding (see Fig. 5). It can be argued therefore that a similar effect could be produced by shifting of the vortex-shedding frequency by means of open-loop excitation at frequencies separated from the resonance frequency. This hypothesis was tested, and the results are discussed in the following section.

#### 4.2. Tone and white noise excitation

Open-loop control was attempted using both discrete tones and white noise. Tones ranging from 64 to 82 Hz were tested. The signal activating the speakers was set at 5 V to match the approximate amplitude of the output signal for feedback control at a gain of 8. It should be noted that there is a 2–3 dB increase in loudspeaker response from 64 to 82 Hz, so the results of these tests are qualitative only. White noise excitation was tested at a range of excitation levels.

Representative examples of spectra produced during these experiments are presented in Fig. 6. Results of the 64, 70 and 76 Hz tones generated by 5 V input are shown, along with those corresponding to the maximum level of white noise excitation. The test results for 64 and 76 Hz are presented because excitation at those two frequencies produced the greatest shifts in vortex-shedding frequency in either direction, i.e., below and above the natural shedding frequency. The 70 Hz case is included for comparison. Spectra corresponding to white noise excitation are also included to compare its effect with that of tone excitation.

Referring to Figs. 6(b) and (c), the most effective shift in vortex-shedding frequency was achieved with a tone excitation at 76 Hz. Vortex shedding was more easily shifted to higher frequencies than lower. Tone excitation at 76 Hz almost completely eliminates the natural vortex shedding at 71 Hz and induces a much stronger peak at 76 Hz. Excitation at 64 Hz creates a small peak at 64 Hz, but leaves a wider-band peak at about 73 Hz. Blevins (1985) found



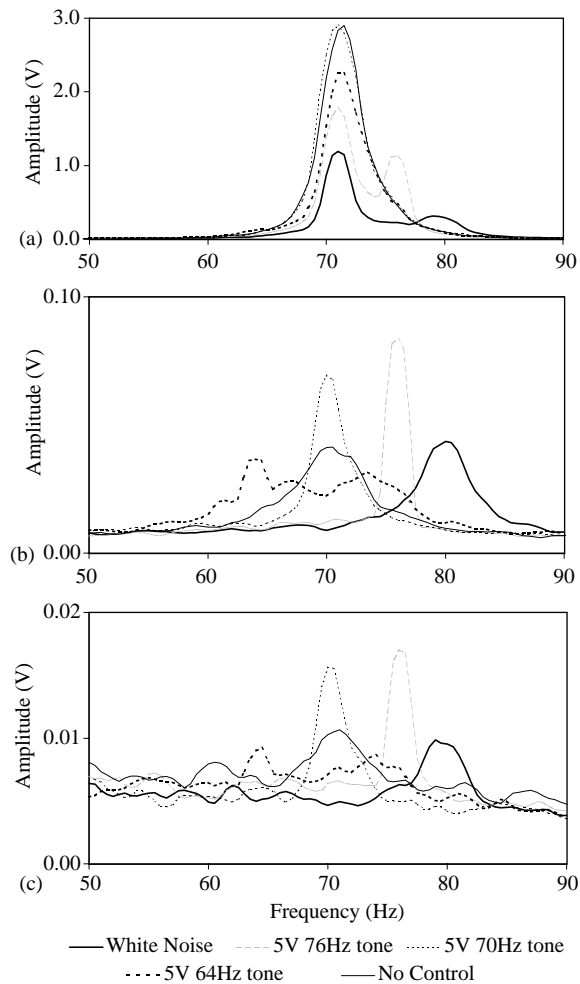

Fig. 6. Spectra of the resonant case showing the effect of open-loop excitation with discrete tones and white noise: (a) force spectra; (b) hotwire between cylinders, Hw1; (c) downstream hotwire, Hw2. —, white noise excitation; - - -, 76 Hz-tone; ·····, 70 Hz-tone; - · - ·, 64 Hz-tone; — — —, no control.

just the opposite in his experiments of externally applied sound fields on vortex shedding from a *single* cylinder. Blevins states that larger shifts in vortex shedding to frequencies below the natural vortex-shedding frequency were possible, than to higher frequencies. This difference is due to the fact that here we have two tandem cylinders, not a single cylinder. Mahir and Rockwell (1996) also reported substantial differences between the forced wake response for single and two tandem cylinders. For the present study, however, it should be noted that the dynamic response of the speaker, which is about 1 dB lower at 64 Hz than at 76 Hz, might have contributed to this phenomenon. This effect, together with the frequency response of the synthetic jet, is currently being investigated.

White noise excitation shifts the frequency of vortex shedding upwards. Higher amplitude white noise creates a greater upward shift in shedding frequency. This agrees with previous observations that the Strouhal number for vortex shedding from circular cylinders rises as the shear layer becomes turbulent. Zdravkovich (1987) illustrates this effect for both smooth and roughened tandem cylinders. For smooth tandem cylinders with  $L/D = 5$ , the Strouhal number rises from a stable value of about 0.2 to about 0.3 as the shear layer becomes turbulent at a Reynolds number of  $4 \times 10^6$ . For a roughened cylinder, a similar rise in Strouhal number occurs, but at a lower Reynolds number of  $8 \times 10^5$ . The Reynolds number of the present tests is below the levels at which the rises in Strouhal number are reported by Zdravkovich, but since white noise is broadband in nature, similar to turbulence, it is bound to cause early transition of the boundary layer on the upstream cylinder. The insertion of turbulence (white noise) into the boundary layer of

upstream cylinder should have an effect similar to roughening the cylinder, and therefore it is expected to have a similar effect as an increase in Reynolds number. It is remarkable that white noise excitation produced a greater shift in shedding frequency than any tone excitation. As can be observed in Figs. 6(b) and (c), not only is the shift greater, but also the intensity of vortex shedding (i.e., velocity fluctuation) is not increased appreciably. For this reason, the force amplitude is reduced more by white noise than by tone excitation, as illustrated in Fig. 6(a).

Considering the force spectra shown in Fig. 6(a), the reduction of transmitted force by open-loop excitation is dependent chiefly on the difference between the frequency of vortex shedding and the resonance frequency of downstream cylinder. The greatest reduction, of 59%, was achieved by white noise excitation, which caused a complete shift of vortex shedding from 71 to 80 Hz. The next best result was for tone excitation at 76 Hz, which caused a complete shift of vortex shedding from 71 to 76 Hz. Excitation at 64 Hz was less successful because it failed to completely shift vortex shedding to 64 Hz; significant velocity fluctuations still occurred near the resonance frequency of downstream cylinder. Excitation at 70 Hz caused a large increase in velocity fluctuations, as shown by the hotwire spectra in Figs. 6(b) and (c), but Fig. 6(a) shows only little change, if any at all, in the force spectrum.

None of these open-loop excitations, even white noise, match the reduction in force amplitude achieved using feedback control. This is despite the fact that feedback control shifted the frequency of vortex shedding far less than white noise. Not only did feedback control not shift vortex shedding as far as white noise, the hotwire spectra in Figs. 5(c) and (d) show significant amplitude of velocity fluctuations near the resonance peak, which is eliminated by both the 76 Hz-tone and the white noise excitations. Thus, it is evident that the mechanism of reducing the force amplitude with feedback control is more complex than just causing a shift in vortex shedding away from the resonance frequency. The nature of the feedback control mechanism, including detailed measurements of the fluctuation velocity field, is currently being investigated.

## 5. Control of the nonresonant case

Experiments were conducted near the maximum flow speed of the wind tunnel. A high speed was desirable to cause vortex shedding at a frequency as far removed as possible from the resonance frequency of the downstream cylinder at 71 Hz. Typical spectra of the hotwire and force signals of this case are shown in Fig. 2(b). Since the vortex-shedding frequency is removed from the resonance frequency, the fluid force component at the resonance frequency of downstream cylinder is generated by *broadband turbulence*, not by organized flow structures such as that associated with vortex shedding. The force signal shown in Fig. 2(b) was used as the control input. This signal contains two spectral peaks, one at the downstream cylinder resonance frequency (71 Hz) and the other is at the vortex-shedding frequency (97 Hz). As will be seen in this section, this approach was successful in controlling both the 71 Hz resonance peak and the 97 Hz vortex-shedding peak simultaneously. The signal from Hw1, see Fig. 2(b), was also used as a control input. This produced comparable reductions in the vortex-shedding peak, but no attenuation in the resonance peak.

Fig. 7 summarizes the effect of controller delay on the ratio of force amplitudes with and without control. It shows the results for both the vortex-shedding component at 97 Hz and the resonance component at 71 Hz. The amplitude ratio of unity on both plots corresponds to the amplitude level without control, providing a basis for comparison. Fig. 7 shows results for a controller gain of 8, which was found to be optimal for all control inputs. To determine the optimal controller gain, a variety of gains were tested for each of the control inputs.

As can be seen from Fig. 7(a), control using the force signal reduced the vortex shedding force component (97 Hz) for all tested values of delay. In addition, at small values of time delay, both force components are reduced substantially. The best overall attenuation was achieved near a delay of 1 ms, resulting in a 47% reduction in the vortex-shedding component and a 57% reduction in the resonance component. Control using the signal from Hw1 for the input reduced vortex-shedding component by 45%, but did not result in any reduction of the resonance component. In other words, the two control signals reduce the vortex-shedding component by approximately equal amounts, but their effects on the resonance component are drastically different. For example, Fig. 7(b) shows a maximum of 75% reduction in the resonance component for the force signal input near a delay of 4 ms, but no reduction at any delay for the Hw1 input. This difference can be explained by examining the frequency content of the force and hotwire signals.

Fig. 8 shows spectra of the force, Hw1 and Hw2 signals, respectively. These spectra correspond to the time delays at which maximum reduction in vortex shedding was achieved. The force signal input produced optimal control at a delay of 1 ms, while the hotwire input produced optimal control at 3 ms. A comparison of Figs. 8(a) and (b) clearly shows the difference in frequency content. Because the resonance peak at 71 Hz in Fig. 8(a) is excited by broadband turbulence, the hotwires do not show any discrete fluctuations at 71 Hz. The 'no control' vortex-shedding peaks at 97 Hz are very similar in all spectra. Thus, the only major difference in the signals is the absence of the 71 Hz-component in the hotwire signal. It is clearly the presence of this component in the force signal input that enables its control.

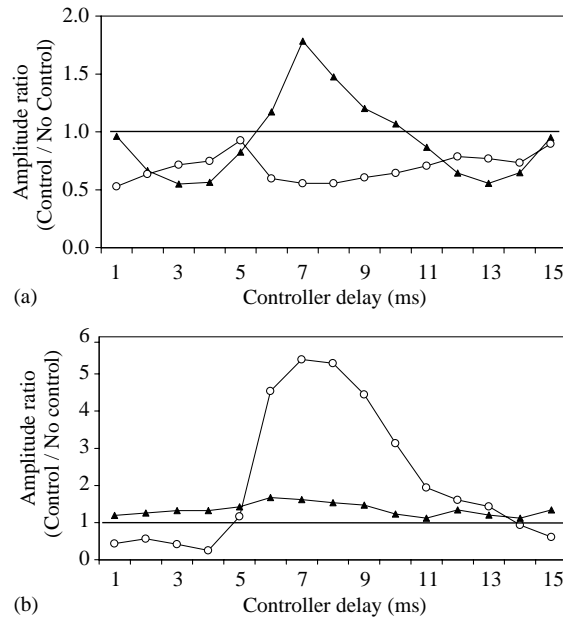

Fig. 7. Summary of amplitude ratio (controlled to uncontrolled) for both frequency components of the force signal. Nonresonant case: (a) amplitude at vortex-shedding frequency (97 Hz); (b) amplitude at resonance frequency (71 Hz).  $\circ$ , force signal as input;  $\blacktriangle$ , hotwire signal as input.

Returning to Fig. 7, the effect of control is seen to be cyclic in this case also, albeit not as clear as in the resonant case. For example, since the hotwire responds to the vortex-shedding component only, which has a frequency of 97 Hz and a period of 10.3 ms, the effect of using it as the control input is seen in Fig. 7(a) to be cyclic with a period slightly larger than 10 ms. When the force signal is used as the control input, Fig. 7(b) shows that the control effect is cyclic with a period of 14 ms, which is the period of the resonance frequency of downstream cylinder. In the latter case, the attenuation of the vortex-shedding component at 97 Hz for time delays between 5 and 12 ms, Fig. 7(a), seems to be caused by the enhancement of the resonant component at 71 Hz and the resulting transfer of fluctuation energy from the 97 Hz component to the enhanced resonance component at 71 Hz.

As mentioned earlier in connection with Fig. 7, with the force signal as input and at small values of time delay, feedback control of the nonresonant case reduces the amplitudes of both the vortex-shedding peak and the resonance peak. The reduction in the resonance peak at 71 Hz cannot be explained by a shift in the vortex-shedding frequency near 97 Hz, since that frequency shift, if there were any, would be too small to cause any noticeable effect on the vibration amplitude at 71 Hz. Indeed, the reduction in the resonance peak has little to do with the reduction in the vortex-shedding peak. As can be seen Fig. 8, neither hotwire spectra shows a peak at 71 Hz, with or without control. The downstream cylinder is excited at its resonance frequency primarily by flow turbulence when vortex shedding occurs at 97 Hz. Why this turbulent buffeting response is reduced by means of the present controller is not clear at present. However, it is proposed that the imposed acoustic excitation produces weak velocity fluctuations, at a favorable phase, which travel downstream and counteracts the turbulent buffeting response of the downstream cylinder. These fluctuations must be so weak that they could not be detected in the turbulent wake of the upstream cylinder. Clearly, this supposition cannot be verified at present because of the lack of detailed measurements of the unsteady velocity field with and without control. It should be mentioned however that the present results provide an interesting new possibility to attenuate turbulence-induced vibration by feedback control means. Further research of the mechanism causing this attenuation is currently underway.

It should be noted here that the effect of control in the nonresonant case is more apparent than in the resonant case. In the latter case, the effect of control on the fluid force acting upon the downstream cylinder is masked by the cylinder resonant response. As discussed earlier in connection with Fig. 5, although the downstream cylinder response and thereby also the transmitted force were reduced, the vortex-shedding peak became narrower and stronger. Thus, the attenuation of the cylinder response and transmitted force does not necessarily entail a reduction in the dynamic lift force acting on the downstream cylinder. In the nonresonant case, however, a decrease in the transmitted force amplitude is a true reduction in the dynamic fluid force on the downstream cylinder.

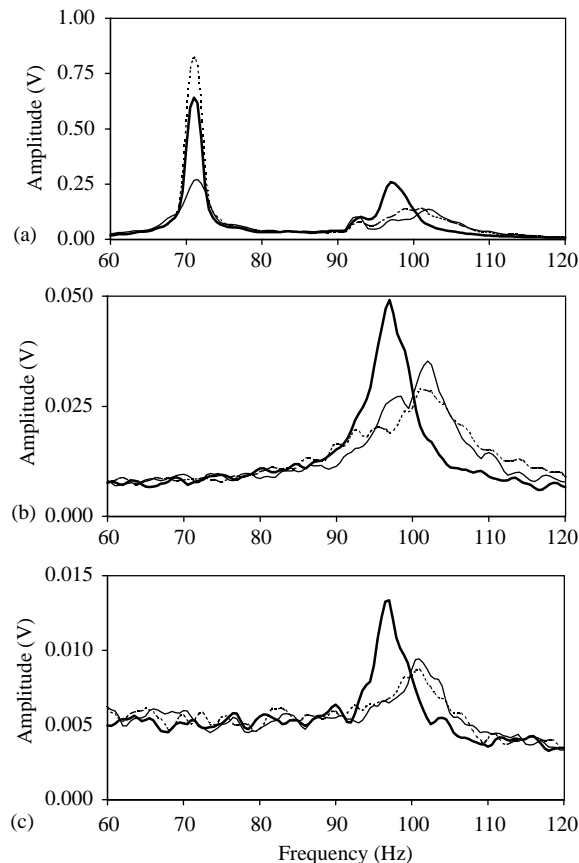

Fig. 8. Typical spectra of the nonresonant case at optimum controller delay: (a) force spectra; (b) hotwire between cylinders (Hw1); and (c) downstream hotwire (Hw2). —, no control; ---, hotwire signal input; —, lift signal input.

## 6. Summary and conclusions

The effect of feedback control on vortex shedding from two tandem cylinders and on the fluid forces acting upon the downstream cylinder was investigated for two flow speeds. The lower flow speed, or the *resonant case*, was chosen because the frequency of vortex shedding matched the resonance frequency of the downstream cylinder. This allowed study of the effect of feedback control on the resonant response of the downstream cylinder induced by vortex shedding. The second flow speed, or the *nonresonant case*, was chosen to raise the vortex-shedding frequency as much as the experimental facility allowed. In this case, the response of the downstream cylinder was dominated by two components. The first was at the resonance frequency of the downstream cylinder and was excited by broadband turbulence, whereas the second was at the vortex-shedding frequency. In both cases, the effect of feedback control was investigated by either using the force signal or the velocity fluctuation signal as input to the controller. A simple controller was used to introduce a gain as well as a time delay. The time delay was used to modify the phase of the control signal. The main findings for each investigated case and control technique are summarized in the following.

### 6.1. Feedback control of the resonant case

For the resonant case, feedback control using the force signal as control input and a time delay of 1 ms reduced the resonant response of the downstream cylinder by an amount of 70%. However, the velocity fluctuation at the vortex-shedding frequency was not reduced in amplitude, rather vortex shedding was shifted to a slightly higher frequency. This frequency shift in the vortex-shedding frequency, away from the resonance frequency of downstream cylinder, appears to be an important element of the mechanism reducing the response of the downstream cylinder.

Feedback control of the resonant case using the hotwire signal as the control input and a time delay of 9 ms reduced the resonant response of the downstream cylinder by only 35%, far less than the 70% reduction achieved with the force signal as control input. However, with the hotwire signal used as control input, the cylinder response was attenuated over a much wider range of time delay than that resulting from using the force signal as control input.

### 6.2. Open-loop control of the resonant case

For the resonant case, shifting the vortex-shedding frequency using open-loop excitation with tones and white noise failed to reduce the resonant response of downstream cylinder as effectively as that produced with feedback control, even though the shift in vortex-shedding frequency was greater in the case of open-loop control. These results underline the fact that the effect of feedback control is more complex than just attributing it to a shift in the vortex-shedding frequency away from the cylinder resonance frequency.

Open-loop excitation with white noise caused larger frequency shifts in vortex-shedding frequency than was possible using pure tone excitation of comparable amplitude. The amount of attenuation of the downstream cylinder response was therefore larger with white noise excitation than with pure tone excitation. The shift in vortex-shedding frequency caused by white noise excitation seems to be the result of boundary layer transition on the upstream cylinder due to the applied sound.

### 6.3. Feedback control of the nonresonant case

For the nonresonant case, feedback control using the force signal as control input reduced the cylinder response at its resonance frequency by a maximum of 75% and at the vortex-shedding frequency by a maximum of 47%. However, these reductions were produced at different settings of the controller time delay. Simultaneous reductions of both frequency components could be achieved for small values of time delay, 1 to 4 ms. The best *simultaneous* reduction achieved was at a time delay of 1 ms and amounted to 47% and 57% in the resonance and vortex-shedding components, respectively. Feedback control using the signal of Hw1 as control input reduced the vortex-shedding component by 45%, but did not suppress the resonance component.

The control mechanism, which attenuates the turbulent buffeting response of downstream cylinder in the nonresonant case, is intriguing and deserves further research. It may provide a new approach to control turbulence-induced vibration by feedback control means, which acts on the flow rather than on the structure. Coherent velocity fluctuations at the cylinder resonance frequency could not be detected in the wake of the upstream cylinder.

### 6.4. Feedback control of the resonant and nonresonant cases

For both the resonant and nonresonant cases, when the force signal was used as the control input, the best reduction in cylinder response was achieved at the smallest time delay, 1 ms. This indicates that an instantaneous control response will likely provide the best control.

The effect of time delay of feedback control is periodic. As the time delay is increased, the downstream cylinder response is attenuated and enhanced in a cyclic manner, with a time-delay cycle approximating the period of the cylinder response. Furthermore, although instantaneous controller response, or the smallest time delay, provides the largest attenuation, effective reduction can also be achieved using a control signal which is delayed by an entire cycle.

## References

- Arie, M., Kiya, M., Moriya, M., Mori, H., 1983. Pressure fluctuations on the surface of two circular cylinders in tandem arrangement. *Journal of Fluids Engineering* 105, 161–167.
- Blevins, R.D., 1985. The effect of sound on vortex shedding from cylinders. *Journal of Fluid Mechanics* 161, 217–237.
- Blevins, R.D., 1990. *Flow-Induced Vibration*, 2nd Edition. Krieger Publishing Company, Malabar, FL.
- Cattafesta III, L.N., Garg, S., Choudhari, M., Li, F., 1997. Active control of flow-induced cavity resonance. AIAA paper no. 97-1804, AIAA, Washington, DC, pp. 1–12.
- Freythuth, P., 1966. On transition in a separated laminar boundary layer. *Journal of Fluid Mechanics* 25, 683–704.
- Hsiao, F., Shyu, J., 1991. Influence of internal acoustic excitation upon flow passing a circular cylinder. *Journal of Fluids and Structures* 5, 427–442.
- Huang, X.Y., 1995. Suppression of vortex shedding from a circular cylinder by internal acoustic excitation. *Journal of Fluids and Structures* 9, 563–570.
- Huang, X.Y., 1996. Feedback control of vortex shedding from a circular cylinder. *Experiments in Fluids* 20, 218–224.

- Huang, X.Y., Weaver, D.S., 1991. On the active control of shear layer oscillations across a cavity in the presence of pipeline acoustic resonance. *Journal of Fluids and Structures* 5, 207–219.
- Huang, X.Y., Weaver, D.S., 1994. Control of flow-induced fin vibration by anti-sound. *Journal of Sound and Vibration* 169, 428–432.
- Huerre, P., Monkewitz, P., 1990. Local and global instabilities in spatially developing flows. *Annual Review of Fluid Mechanics* 22, 473–537.
- King, R., 1977. A review of vortex shedding research and its applications. *Ocean Engineering* 4, 141–171.
- Mahir, N., Rockwell, D., 1996. Vortex formation from a forced system of two cylinders—Part I: tandem arrangement. *Journal of Fluids and Structures* 10, 473–489.
- Miksad, R.W., 1972. Experiments on the nonlinear stages of free-shear-layer transition. *Journal of Fluid Mechanics* 59, 695–719.
- Nakano, M., Rockwell, D., 1993. The wake from a cylinder subjected to amplitude-modulated excitation. *Journal of Fluid Mechanics* 247, 79–110.
- Nakano, M., Rockwell, D., 1994. Flow structure in the frequency-modulated wake of a cylinder. *Journal of Fluid Mechanics* 266, 93–119.
- Peterka, J., Richardson, P., 1969. Effects of sound on separated flows. *Journal of Fluid Mechanics* 37, 265–287.
- Rockwell, D., Naudascher, E., 1979. Self-sustained oscillations of impinging free shear layers. *Annual Review of Fluid Mechanics* 11, 67–94.
- Roussopoulos, K., 1993. Feedback control of vortex shedding at low Reynolds numbers. *Journal of Fluid Mechanics* 248, 267–296.
- Sarno, R.L., Franke, M.E., 1994. Suppression of flow-induced pressure oscillations in cavities. *Journal of Aircraft* 31, 90–96.
- Schumm, M., Berger, E., Monkewitz, P., 1994. Self-excited oscillations in the wake of two-dimensional bluff bodies and their control. *Journal of Fluid Mechanics* 271, 17–53.
- Tanida, Y., Okajima, A., Watanabe, Y., 1973. Stability of a circular cylinder oscillating in uniform flow or in a wake. *Journal of Fluid Mechanics* 61, 769–784.
- Thomson, W.T., Dahleh, M.D., 1998. *Theory of Vibration with Applications*, 5th Edition.. Prentice-Hall, Englewood Cliffs, NJ.
- Tokumaru, P., Dimotakis, P., 1991. Rotary oscillation control of a cylinder wake. *Journal of Fluid Mechanics* 224, 77–90.
- Warui, H., Fujisawa, N., 1996. Feedback control of vortex shedding from a circular cylinder by cross-flow cylinder oscillations. *Experiments In Fluids* 21, 49–56.
- Williams, D., Mansy, H., Amato, C., 1992. The response and symmetry properties of a cylinder wake subjected to localized surface excitations. *Journal of Fluid Mechanics* 234, 71–96.
- Wiltze, J.M., Glezer, A., 1993. Manipulation of free shear flows using piezoelectric actuators. *Journal of Fluid Mechanics* 249, 261–285.
- Wolfe, D., 2000. Feedback control of vortex shedding from two tandem cylinders. Master's Thesis, McMaster University, Hamilton, Ontario, Canada.
- Zdravkovich, M., 1977. Review of flow interference between two circular cylinders in various arrangements. *ASME Journal of Fluids Engineering* 99, 618–633.
- Zdravkovich, M., 1985. Flow induced oscillations of two interfering circular cylinders. *Journal of Sound and Vibration* 101, 511–521.
- Zdravkovich, M., 1987. The effects of interference between circular cylinders in cross flow. *Journal of Fluids and Structures* 1, 239–261.
- Ziada, S., 1995. Feedback control of globally unstable flows: impinging flows. *Journal of Fluids and Structures* 9, 907–923.
- Ziada, S., 1999. Feedback control of global flow oscillations. *Engineering Mechanics* 6, 337–354.
- Ziada, S., 2001. Interaction of a jet-slot oscillator and a deep-cavity resonator and its control. *Journal of Fluids and Structures* 15, 831–843.
- Ziada, S., 2002. Feedback control of a planar jet impinging on a flexible wedge. *Journal of Fluids and Structures* 16, 613–626.